

SALES DRAWING

SALES DRAWING

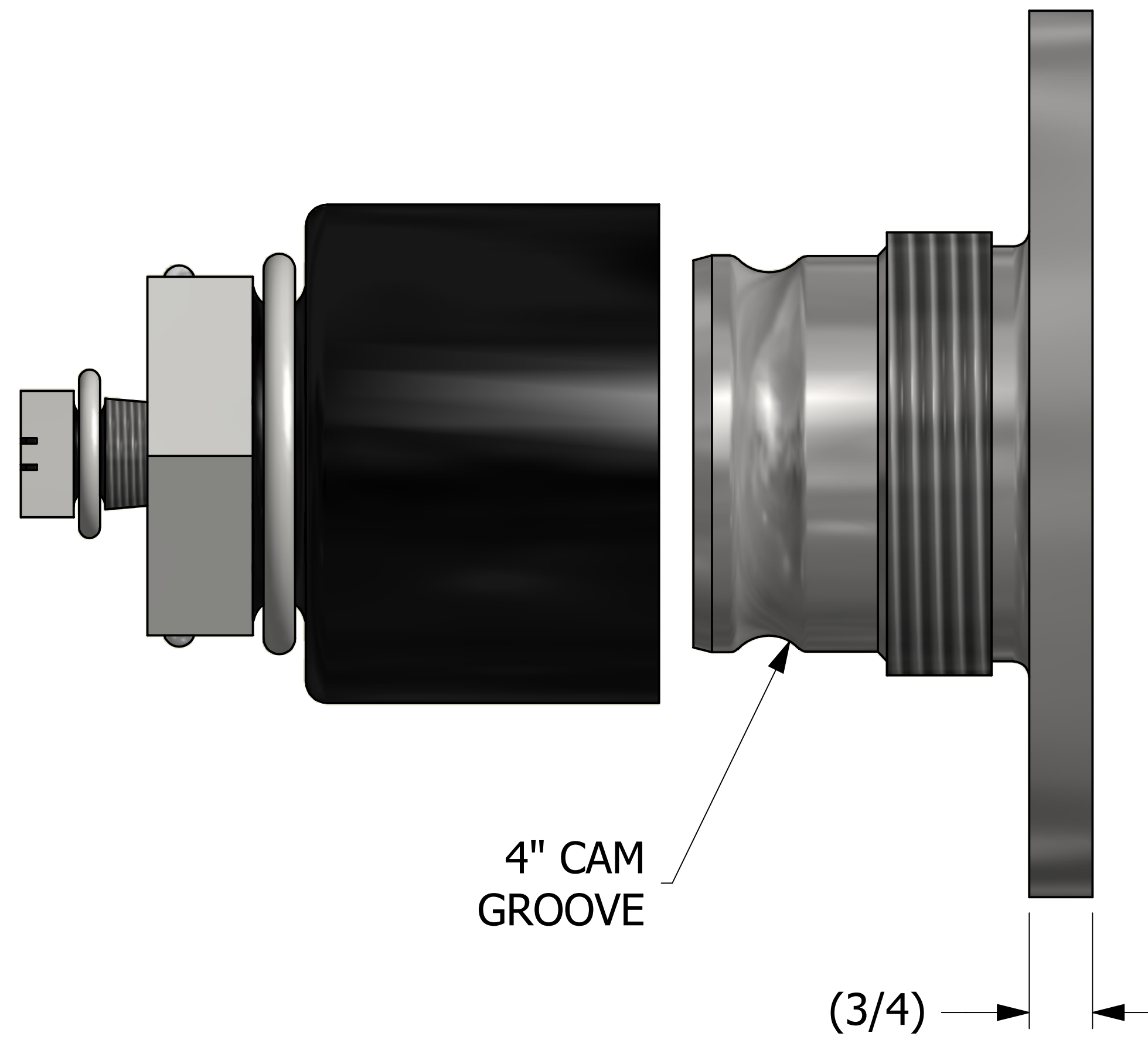
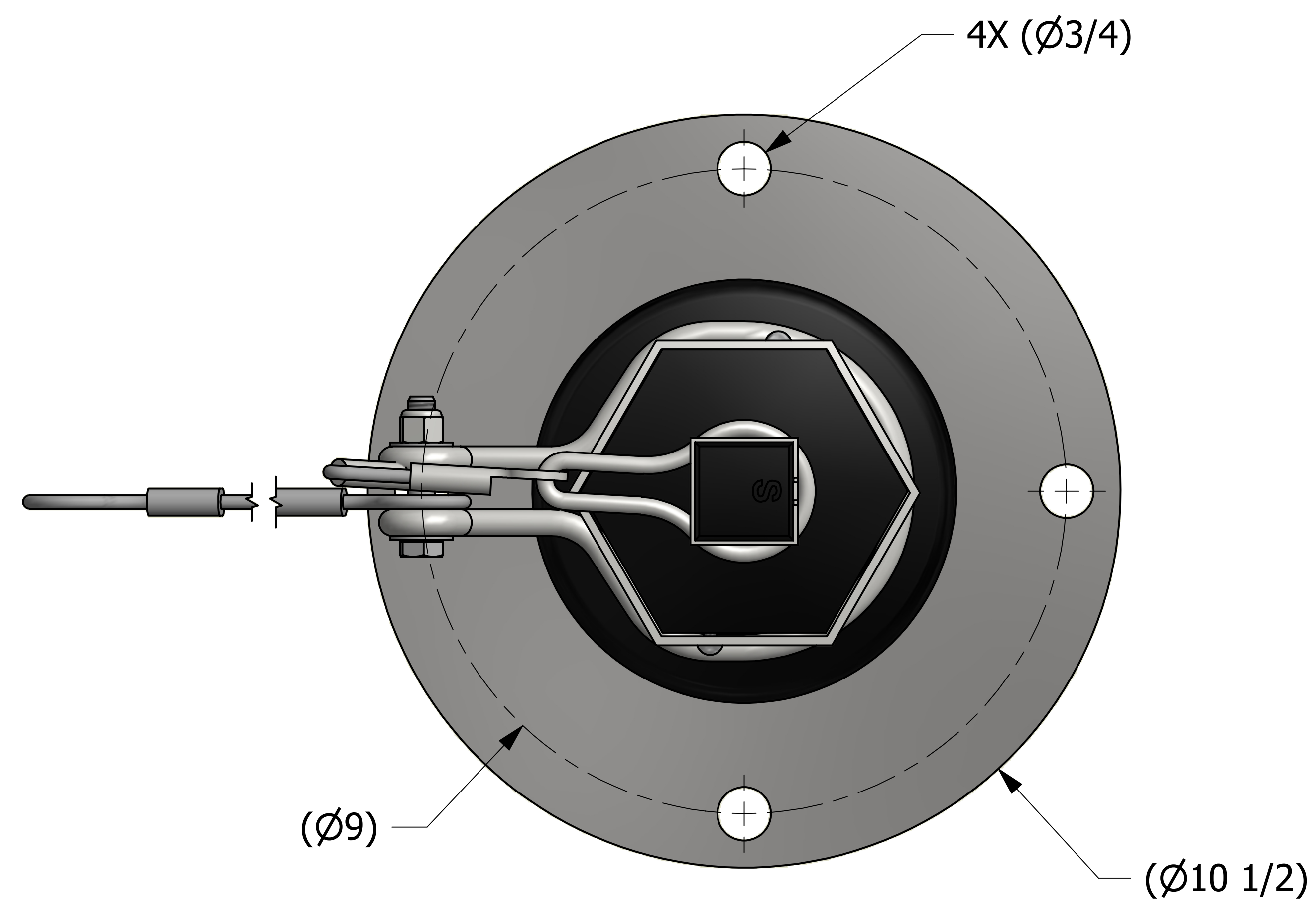

NOTES:

1. APPROXIMATE HEIGHT = 8"
2. FLANGE AAR APPROVAL# E-149523.
3. CAP AAR APPROVAL# E-119003.
4. THIS ASSEMBLY IS NOT DOT APPROVED AND CAN BE USED ONLY ON AAR STENCILED CARS.
5. FLANGE MATERIAL IS 316 SS.
6. CAP MATERIAL IS NYLON 6/6.
7. CAP GASKET IS BLACK NITRILE.
8. FITS 4" JAMESBURY BALL VALVE (9.00" B.C.).

B	WEB	1-23-15	AAR APPROVAL # WAS E-049013
A	JG	12-10-14	RELEASED FOR PRODUCTION
REV	BY	DATE	DESCRIPTION

<small>UNLESS OTHERWISE SPECIFIED DIMENSIONAL TOLERANCES</small> FRACTIONAL: ±1/16 X.XX: ±.03 X.XXX: ±.015 ANGULAR: ±1° DEBURR ALL SHARP EDGES. ALL MACHINED SURFACES TO HAVE A 125 RMS FINISH UNLESS NOTED OTHERWISE. <small>THIRD ANGLE PROJECTION</small>	DRAWN BY:	JG
	CHECKED BY:	CHL
	PROTOTYPE BY:	JG
	PROTOTYPE DATE:	10/20/2014
	APPROVED FOR PRODUCTION BY:	CHL
	PRODUCTION DATE:	12/10/2014

**SALCO PRODUCTS, INC.**

**QUICK CONNECT 4" FLANGED**

MATERIAL: **SEE NOTES**

PROJECT #:	R1410281	SHEET #:	1 OF 1	SCALE:	1:1
DRAWING #:	D40205	PART #:	TE4NYSF01A		

THIS PRINT, PROPERTY OF SALCO PRODUCTS INC. CONTAINS PROPRIETARY INFORMATION AND MUST NOT BE COPIED, REPRODUCED, OR USED DETRIMENTALLY TO OUR INTEREST.